



CONERGY

Photovoltaic modules | Technical Data

Conergy P 170-180M

High durability in rigorous conditions

The Conergy solar modules P 170 M, P 175M and P 180M are designed for large electrical power requirements. Its high-quality properties facilitate its use in a wide range of applications. Extremely powerful and reliable these modules have high-efficient monocrystalline cells.

- | Cells embedded in EVA (ethylene vinyl acetate) ensure a long-term performance
- | Solar glass on the front side raises the UV resistance and improves the insulation
- | Using waterproof film extends the outdoor use
- | Its sturdy, screwed aluminium offers a higher resistance
- | Modules are equipped with MC IV connectors to enable problem-free installation interconnection
- | With a 5 year product warranty¹, the modules have high-efficiency and long-lasting operating time
- | 12 year warranty on 90 % of the minimum power¹
- | 25 year warranty on 80 % of the minimum power¹
- | IEC 61215 and IEC 61730 in process



Solar tracker



Solar home



Power plant

These modules can be used in a wide range of applications. Ideal for power plant, solar home, tracker or flat roof these modules offer you the best solution for your On-Grid installation.

We suggest you connect this module with one of our reliable and flexible IPG Inverters. For every type and sizes of application, we offer secure and durable mounting systems. Whether pitched roof, flat roof, open field, pole top or custom-made installation – Conergy mounting systems are designed to suit all individual requirements.

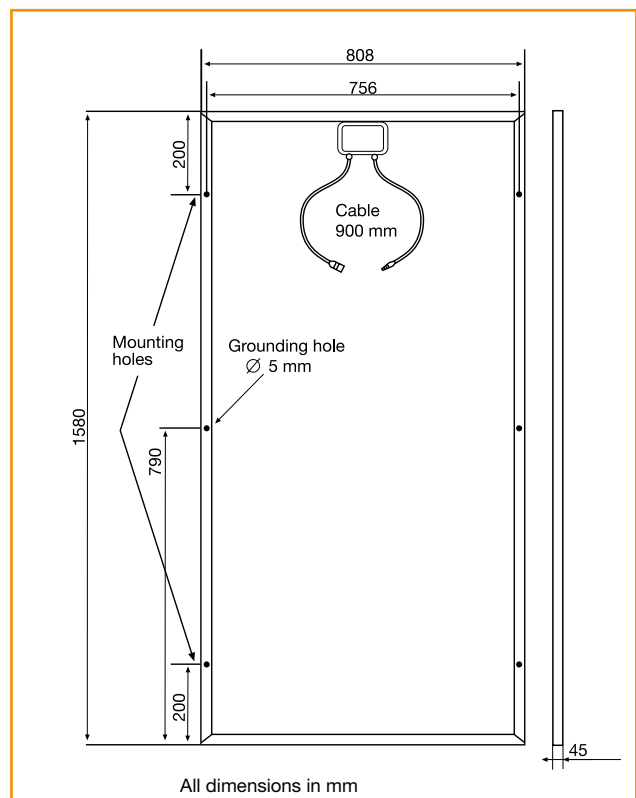
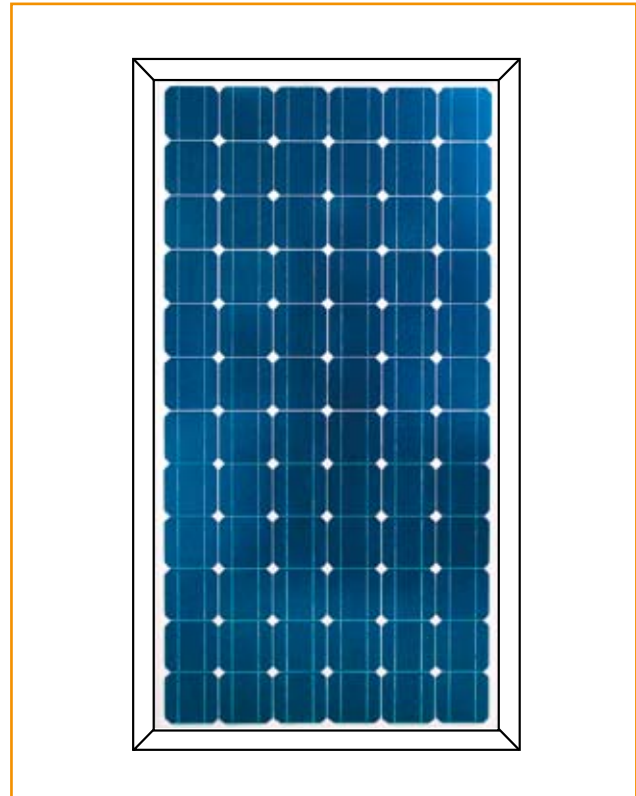

¹ According to current Conergy warranty conditions.



CONERGY

Photovoltaic modules | Technical Data

Conergy P 170-180M

| Electrical specifications | P 170 M | P 175 M | P 180 M |
|---|---------------------|---------------------|---------------------|
| Nom. power (P_{NOM}) as per STC ² | 170 W | 175 W | 180 W |
| Tolerance | ±3 % | ±3 % | ±3 % |
| Module efficiency | 13.3 % | 13.7 % | 14 % |
| MPP voltage (V_{MPP}) | 35.9 V | 36 V | 36 V |
| MPP current (I_{MPP}) | 4.74 A | 4.86 A | 5 A |
| Open circuit voltage (V_{OC}) | 44.5 V | 44.8 V | 45 V |
| Short circuit current (I_{SC}) | 5.12 A | 5.17 A | 5.2 A |
| Temperature coefficient (P_{MPP}) | -0.4 %/°C | -0.4 %/°C | -0.4 %/°C |
| Temperature coefficient (V_{OC}) | -0.169 V/°C | -0.17 V/°C | -0.171 V/°C |
| Temperature coefficient (V_{OC}) | -0.38 %/°C | -0.38 %/°C | -0.38 %/°C |
| Temperature coefficient (I_{SC}) | 2 mA/°C | 2 mA/°C | 2 mA/°C |
| Temperature coefficient (I_{SC}) | 0.04 %/°C | 0.04 %/°C | 0.04 %/°C |
| Maximum system voltage | 748 V | 748 V | 748 V |
| Cells specifications | | | |
| Cells | monocrystalline | monocrystalline | monocrystalline |
| Number of cells | 72 | 72 | 72 |
| Cell dimensions | 125 × 125 mm | 125 × 125 mm | 125 × 125 mm |
| Module dimensions | | | |
| Dimensions (L × W × H) | 1,580 × 808 × 45 mm | 1,580 × 808 × 45 mm | 1,580 × 808 × 45 mm |
| Weight | 15 kg | 15 kg | 15 kg |
| Junction box | | | |
| Dimensions (L × W × H) | 143 × 140 × 28 mm | 143 × 140 × 28 mm | 143 × 140 × 28 mm |
| Safety rating | IP 65 | IP 65 | IP 65 |
| DC plugs | MC IV | MC IV | MC IV |

Available from:

¹ Standard Test Conditions, which are defined as follows: radiation output of 1,000W/m² at a spectral density of AM 1.5 (ASTM E892). Cell temperature of 25 °C

² Normal Operating Cell Temperature: under 800W/M², air masse 1.5 spectrum, wind velocity 1 m/s, T amb. 20 °C